



# **MIXED WOOD AND STEEL GUARDRAIL**

**T 22**  
Patented

## **TECHNICAL SPECIFICATIONS**



**February 2006**

## **SUMMARY**

### **1 - SPECIFICATIONS AND SYSTEM DESCRIPTION**

### **2 – GUARDRAIL SYSTEM ANALYSIS**

### **3 – INSTALLATION DESIGN CRITERIA**

3.1 Design Distance from Rail Face to « fixed-deadly-object”

3.2 Design Distance for Drop-off or significant change in Shoulder Elevation behind Rail Face

3.3 Minimal length for Full Guardrail Barrier System Strength Development

3.4 Specific Topographic Considerations

- Curvature

- Standard System End Treatments

- Connections to existing road structures

- End Treatments for guardrail to Wall , Parapet or Bridge Abutment

### **4 – GUARDRAIL ASSEMBLY SPECIFICATIONS**

4.1 Steel Posts

4.2 Rail Service Height

4.3 Installation Considerations

### **5 – GUARDRAIL SYSTEM COMPONENTS**

5.1 Listing and Description of major Components

5.2 Materials Description

5.3 Dimensions and Tolerances

5.4 Manufacturer Identification Marking

5.5 Components Nomenclature

# MIXED WOOD AND STEEL GUARDRAIL MODEL « T 22 »

## 1 - SPECIFICATIONS AND SYSTEM DESCRIPTION

**This guardrail system addresses a number of issues such as :**

- aesthetically pleasing appearance,
- energy absorption properties of wood,
- composite nature of the wood-steel design allows full development of the strengths natural to both materials while minimizing the inherent weaknesses of wood and of steel,
- ease of installation by the use of standard material,

### **Brief description :**

- guardrail system supported by steel posts C 100 ,
- wood spacer blocks with diameter 18 cm « TE 18 »,
- 4 meters long steel-backed wooden rails, model T 22 with diameter 22 cm half round log,
- 2 meters long steel-backed wooden may be used for specific configurations,
- steel fishplates U 62 joining guardrails at post locations ,
- butt straps TL 22 reinforcing the fishplates attached at the ends of the individual rail sections,
- fastener connection hardware with 5 diameter 16 bolt sets per joint detail. Two per rail are factory pre-assembled.

### **Crash Worthiness**

The mixed wood and steel guardrail T 22 has been tested both privately and independently by LIER ( French Laboratory of “ Essais Inrets Equipements de la Route”).

Said crash tests have been conducted in accordance with European Standard EN 1317, parts 1 and 2 . The crash tests , successfully performed (TB 11 and TB 32), met containment level N2 of the Standard.

	<b>Vehicle Weigth</b>	<b>Speed</b>	<b>Impact angle</b>
TB 11	900 kg	100 km/h	20°
TB 32	1500 kg	110 km/h	20°

## **2 – GUARDRAIL SYSTEM ANALYSIS**

The mixed wood and steel guardrail achieve its performance service due to the “breakaway” design of the post-to-rail connection detail. After the impact, as the vehicle “rides” down the rail, the head of the post-to-rail connection bolt shears through the “fuse-box” fabricated steel connection assembly thus allowing the post to “fold” away when encountered by the impact vehicle. The system “breakaway” feature allows the rail to form a pocket which captures, guides and direct the vehicle back toward the highway.

## **3 – INSTALLATION DESIGN CRITERIA**

### **3.1 – DESIGN DISTANCE FROM RAIL FACE TO “FIXED-DEADLY-OBJECT”**

According the working width of the system , a distance  $d_1$  (figure 7) of 1.90 m ( $W \leq 2.10\text{m}$ ) is necessary to the functioning of the system (space between the front of the device and the front face of the obstacle).

Remark:

For distances less than 1.90 m , the post count should be doubled on two 4m rails , upstream and downstream of the “ fixed-deadly-object”.

### **3.2 – DESIGN DISTANCE FOR DROP-OFF or significant change in Shoulder Elevation behind Rail Face**

The distance  $d_2$  (figure 7) between rail face and the drop-off has to be equal to 1,50 m.

Remark:

For distances less than 1.50 m , the post count should be doubled.

### **3.3 - MINIMAL LENGTH for Full Guardrail System Strength Development**

The minimal length resuired is 60 m, end terminals not included, in order to assure correct anchorage of the system. For shorter lengths, it is recommended to use 2 m rails with posts every 2 m.

### **3.4 – SPECIFIC TOPOGRAPHIC CONSIDERATIONS**

#### **- CURVATURES**

Fishplates TL 62 oblongs holes allow to cover a  $15^\circ$  angle between 2 rails devices in the horizontal or vertical plan. Therefore, it is possible to follow easily highway horizontal or vertical curvature.

For lower radius curves, it is recommended to use 2 m rails.

#### **- STANDARD SYSTEM END TREATMENTS**

The system is terminated with one standard 4 m rail buried in the ground and bolted to the steel post according to the assembly showed in figure 9.

#### **- CONNECTIONS TO EXISTING ROAD STRUCTURES**

There are no specific difficulties and connections require individual design treatments, eventually based on the manufacturer’s recommendations or local regulations.

#### **- END TREATMENTS TO WALL, PARAPET OR BRIDGE ABUTMENT**

No specific design connections details are offered. End Treatments attachments can be designed and provided on a case by case basis.

## **4 - GUARDRAIL ASSEMBLY SPECIFICATIONS**

### **4.1 - STEEL POSTS**

The standard post is 2 m in length. Soil conditions should allow for the post to develop sufficient strength.

### **4.2 - RAIL SERVICE HEIGHT**

The center-line of the rail face should be 70 cm (+ 0.5 cm) above the average elevation of the road shoulder in a 50 cm wide band in front of the said rail.

At no time should the center-line of the rail face be less than 55 cm above the average elevation of the road shoulder in front of the rail section in question.

### **4.3 - INSTALLATION CONSIDERATIONS**

The posts C 100 have to be driven into the ground such that the center-line of the rail shall be no more than 70 cm.

The wood spacers TE 18 are placed on the support posts. Rail sections T22/ 4M are joined and attached to the posts with the fishplates U 62. Two butt-straps TL 22 are attached to each fishplate U 62. Connection hardware and fasteners are kept “loose” until multiple sections of rail are in place allowing for final adjustment of rail configuration. After final rail adjustment, all hardware should be tightened.

## **5 - GUARDRAIL SYSTEMS COMPONENTS**

### **5.1 - LISTING AND DESCRIPTION OF MAJOR COMPONENTS**

- STEEL POST C 100 x 50 x 25 x 5 mm, length 2 m.
- WOOD SPACER BLOCK TE 18 with notch for support post.
- GUARD RAIL TYPE T 22/4M, T 22/4MS2, T22/2M according to their length.  
The rails as per Figure 6 are half round treated wood with embedded steel U-channel, factory bolted into place with 2 bolt sets at each rail section end as per Figure 5. Installation only requires attachment of “fishplate” to each rail section end and the post “through” bolt.
- FISHPLATE U 62, described in figure 4 is a structural steel U channel 100 x 50 x 620 mm in length. Welded to the post side of the fishplate is the fabricated steel connection box (“fuse box”) which accepts the head of the post “through” bolt.
- FISHPLATES TL 22 (butt-straps) is a structural steel 60 x 4 x 220 mm. in length.
- BOLTS TRCC M16 x 140 or M16 x 120, with round head and square nut.

## 5.2 - MATERIALS

### THE WOOD

**Species of wood** for use as guard rails and spacer block shall be Scots Pine, Douglas Pine, Larch, Spruce or Epicea Krast (Black Spruce or Laricio). Excluded is Pinus Pinaster, a resin bearing pine because of its weak impact resilience.

#### **Technical qualities :**

The minimum qualities required are the following :

- growth ring shall be 10 mm wide, measured on five sequential rings at one end of wood component,
- maximum diameter of knots measured perpendicularly to the generating line should not exceed 7 cm in the running parts, 3 cm in the last 35 cm to the end of the wood component,
- wood components shall not have evidence of fungi or insect decay,
- moisture content after treatment and drying shall not exceed 20%.

#### **Mechanical properties :**

- for the rail components, minimum Modulus of Elasticity E shall be 7580 Mpa and minimum Allowable Bending Stress Fb shall be 4.65 Mpa,
- for spacers, minimum Modulus of Elasticity shall be 6985 Mpa and Modulus of Rupture MOR shall be 48,925 or greater.

#### **Preserving treatment :**

Wood components rails and spacer blocks shall have a preserving treatment corresponding to classes 3 or 4 of European norm EN 335 for biological contamination with preservation products defined by the European norm EN 599. Note, the wood components of the system are not in contact with ground.

### THE METAL

- **All the metal parts, except the fasteners**, are steel. All steel components shall be fit for hot -dip galvanizing (EN ISO 1461) and its mechanical characteristics are at least equal to the steel quality S 235 JR, as defined in the European norm EN 10025.
- **The steel posts are standard C 100** certified NF( French Norm) road equipment or similar.
- **The metal for fasteners** is defined as follows :
  - the screw bolts shall be of quality 5.6,
  - the screw nuts shall be of quality 5,The quality class is defined by French norm NF E 27 005.
- **Protection against the corrosion**  
All steel components (included fasteners) should be protected against corrosion by hot -dip galvanization according as per standard specification EN ISO 1461.

### **5.3 - DIMENSIONS AND TOLERANCES**

All the sizes and tolerances of the drawings are in millimetres, even when not specified.

**For wood components** (measured at 20% of humidity)

- diameter 18 cm (-0, +0.5 cm)
- length of the wood 399 cm (+or -0.5 cm)
- rectitude : admitted tolerance is of 1% of the maximum length
- gap or space between rail sections at the joints shall be 1 cm.

**For steel components**

- holes (+ or -0.5 mm)
- center to center distances (+ or -2 mm)
- length of steel reinforcing components (+ or -5 mm)

### **5.4 – MANUFACTURER IDENTIFICATION MARKING**

Each rail section shall be marked by a letter stamp to read « T22 », and the year of manufacture.

## 5.5 -COMPONENTS NOMENCLATURE

DESIGNATION	CODE	CHARACTERISTICS
Steel Post	C 100	Standardized support C 100x50x25x5 mm Length = 2000 mm
Wooden spacer	TE 18	Spacer Diam.18 cm drilled and embedable
Model T guard rail	T22/4M*	Diameter 22 cm, length 4000 mm - 1 U channel 90x45x4 mm length 3920 mm - 4 bolts welded to the U channel - 1 pressure treated half round log, length 3980 mm drilled with 4 holes * factory-assembled
Model T guard rail	T22/2M*	Diameter 22 cm, length 2000 mm - 1 U channel 90x50x4 mm length 1920 mm - 4 bolts welded to the U channel - 1 pressure treated half round log, length 1980 mm drilled with 2 holes * factory-assembled
Back Fishplate	U 62	Structural steel U channel 80x10 mm, length 620 mm 1 steel connection box welded
Reinforcing fishplate (butt-strap)	TL 22	Structural steel 60x4 mm, length 220 mm
Intermediate fishplate for T22/4MS2	TL 5	Structural steel 80 x 10 mm, length 380 mm 1 steel connection box welded
Bolts	TRCC M16x140 M16x110 M16x120	Round head bolts and square nuts
Nuts	M 16	
Fishplate for buried terminals	TL 41	Structural steel 80x10 mm, length 410 mm



**SCHEME 1 : SYSTEM ELEVATION**

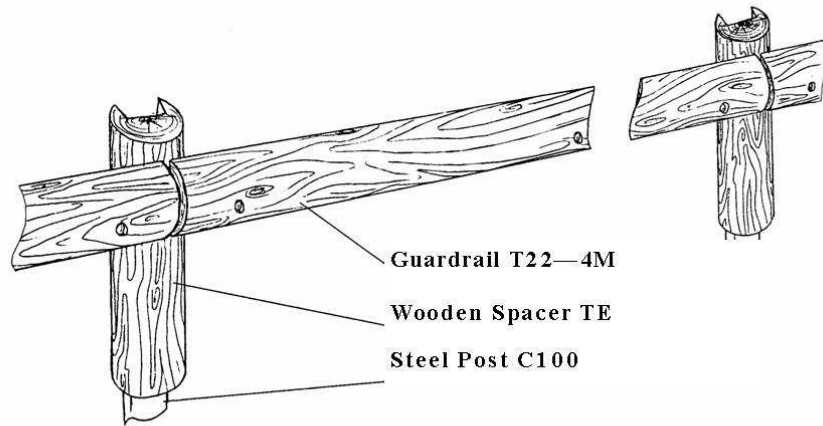

**SCHEME 2 : VIEW OF CONNECTION**

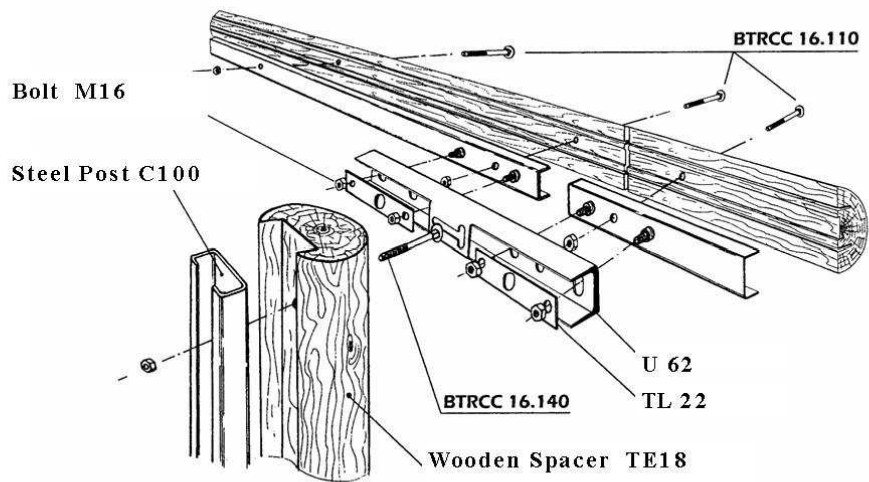

**SCHEME 3 : OVERALL NEW**

**Post C100**  
**Wooden Post TE18**  
**Guardrail T22-4M**

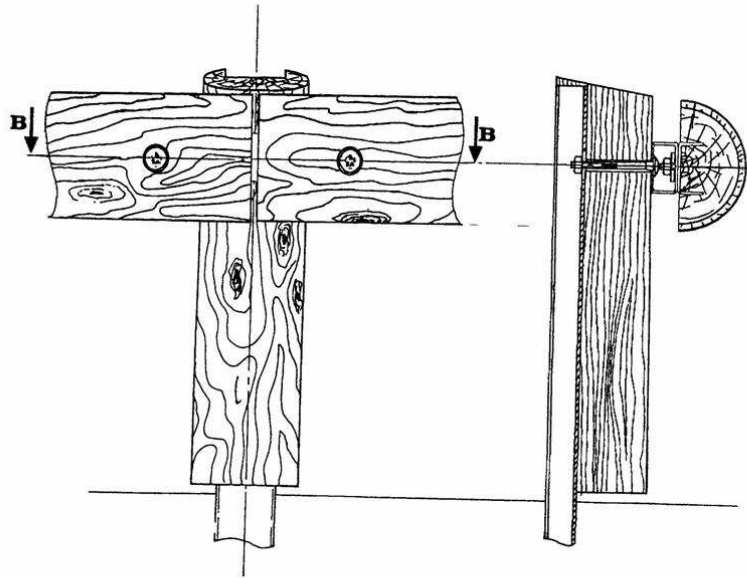

**CROSS SECTION BB**

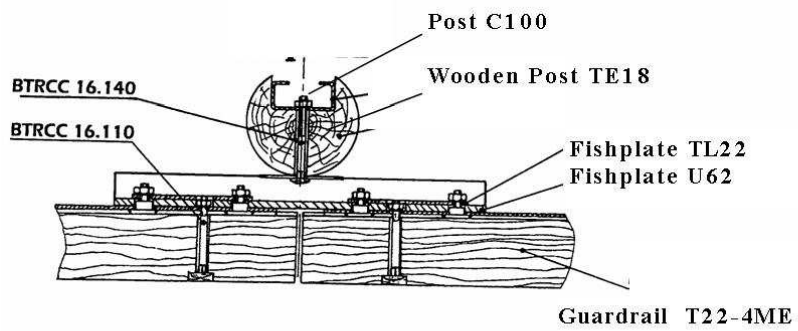

**SCHEME 4 : FISHPLATE TL 22 AND U62**

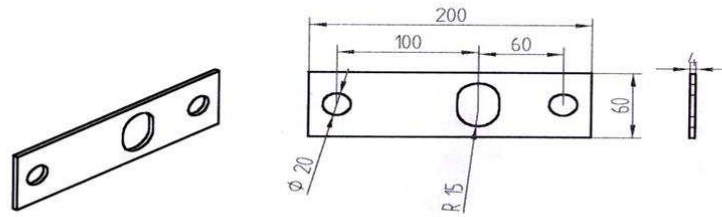

**TL 22**

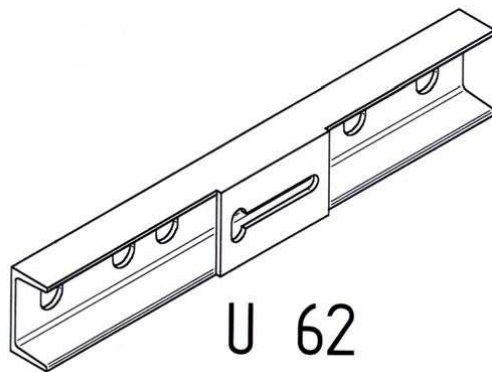
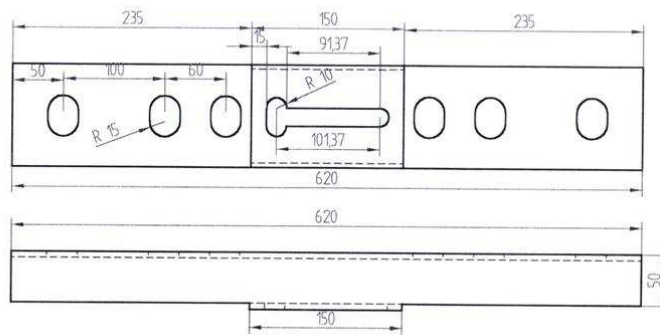

**U 62**

**SCHEME 5 : U CHANNEL**

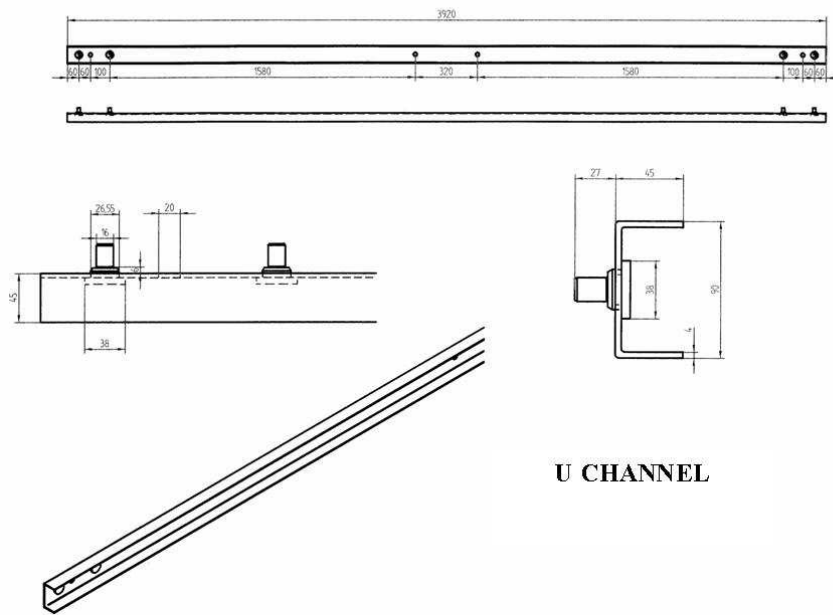

**U CHANNEL**

SCHEME 6 : GUARDRAIL 4M

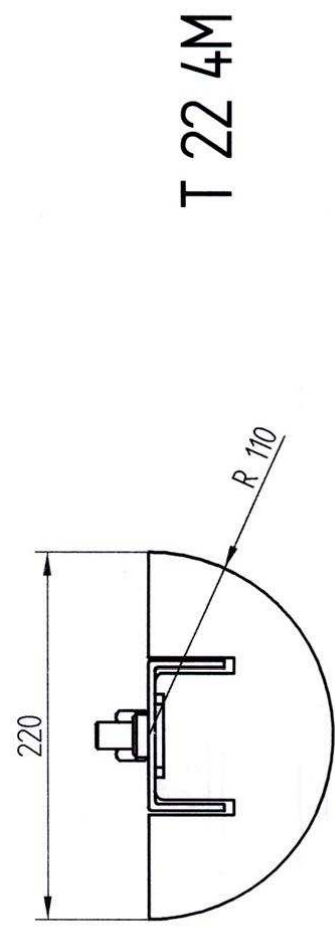
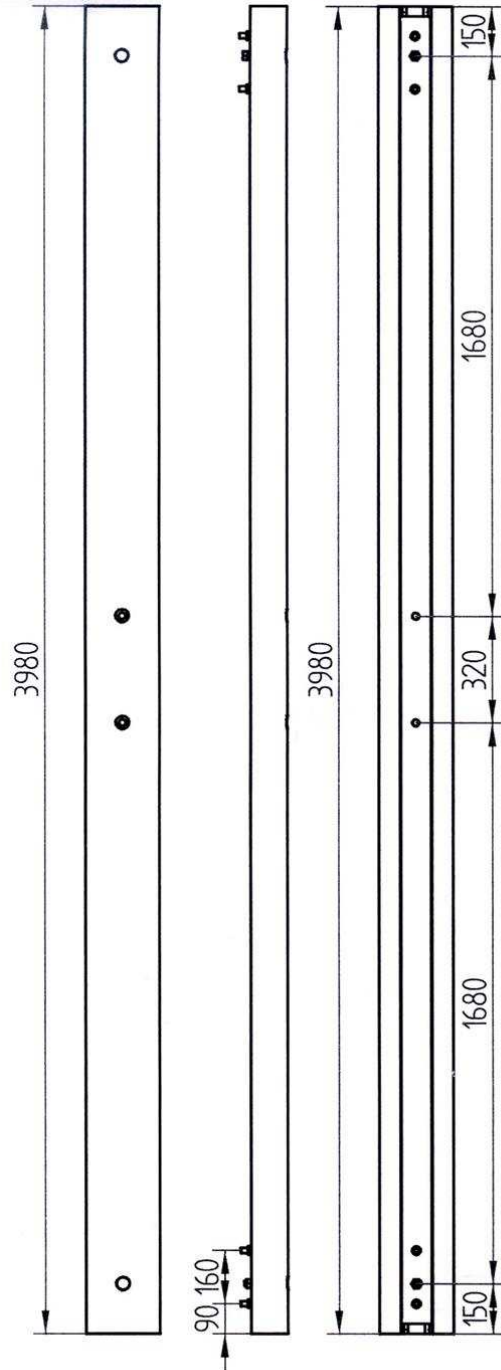

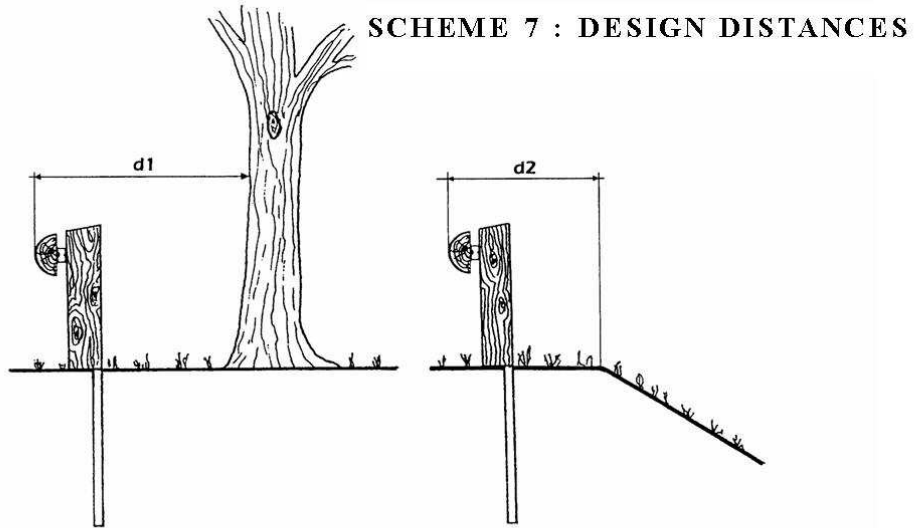

**SCHEME 8 : CONNECTION OF THE ANCHOR SYSTEM**

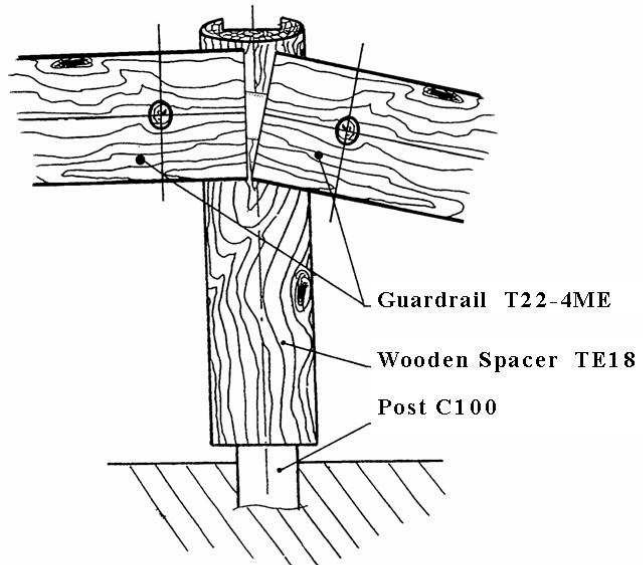

**SCHEME 9 : OVERALL VIEW OF THE ANCHOR SYSTEM**

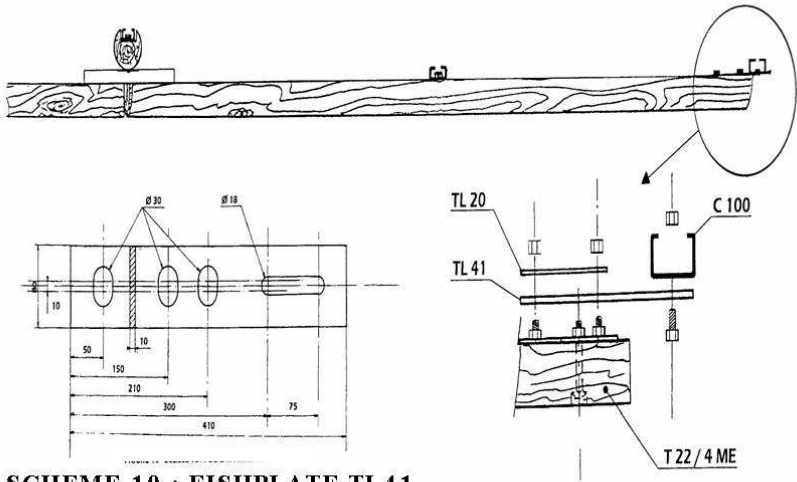
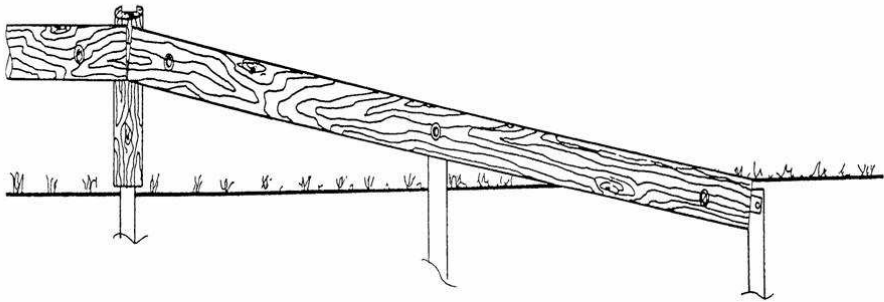

**SCHEME 10 : FISHPLATE TL41 OF THE ANCHOR SYSTEM**