

KREMSBARRIER B RH2 A

Road Restraint System suitable
for pile driving ground conditions

product specifications Sheet CB01/1

Tested in accordance with EN 1317-2:

containment level: H2
impact severity level: B
working width: W4
system test length: 14 cells or 56,00m, without driving

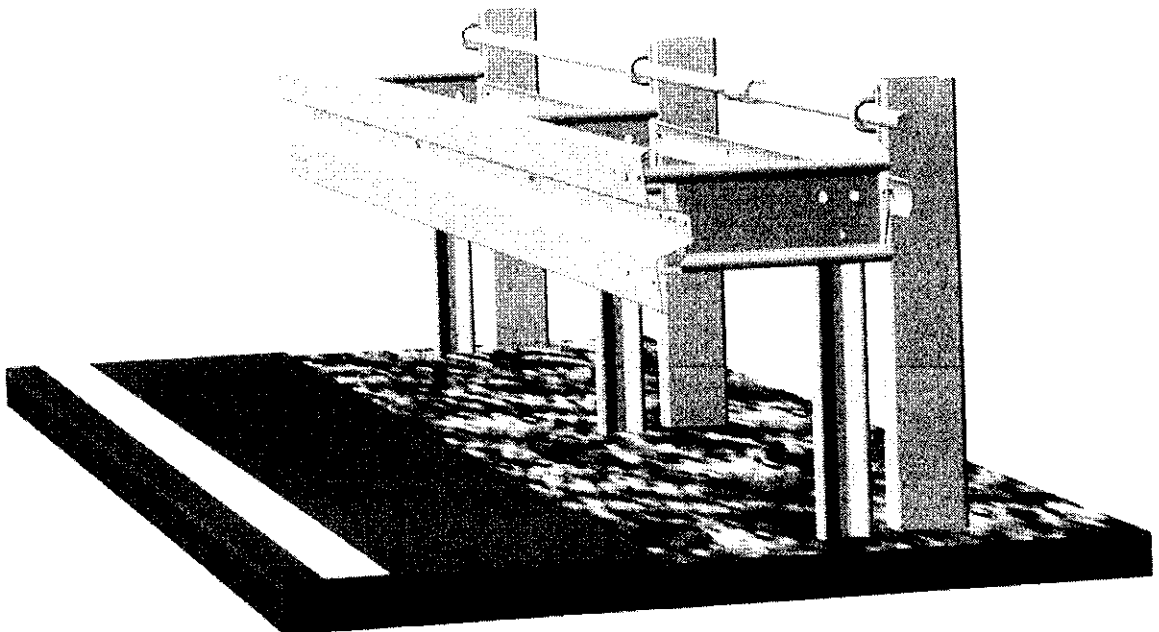

LS Oktober 2007

KREMSBARRIER B RH2 A

Road Restraint System suitable
for pile driving ground conditions

product specifications Sheet CB01/2

terminal as per drawing type CB02, CB03

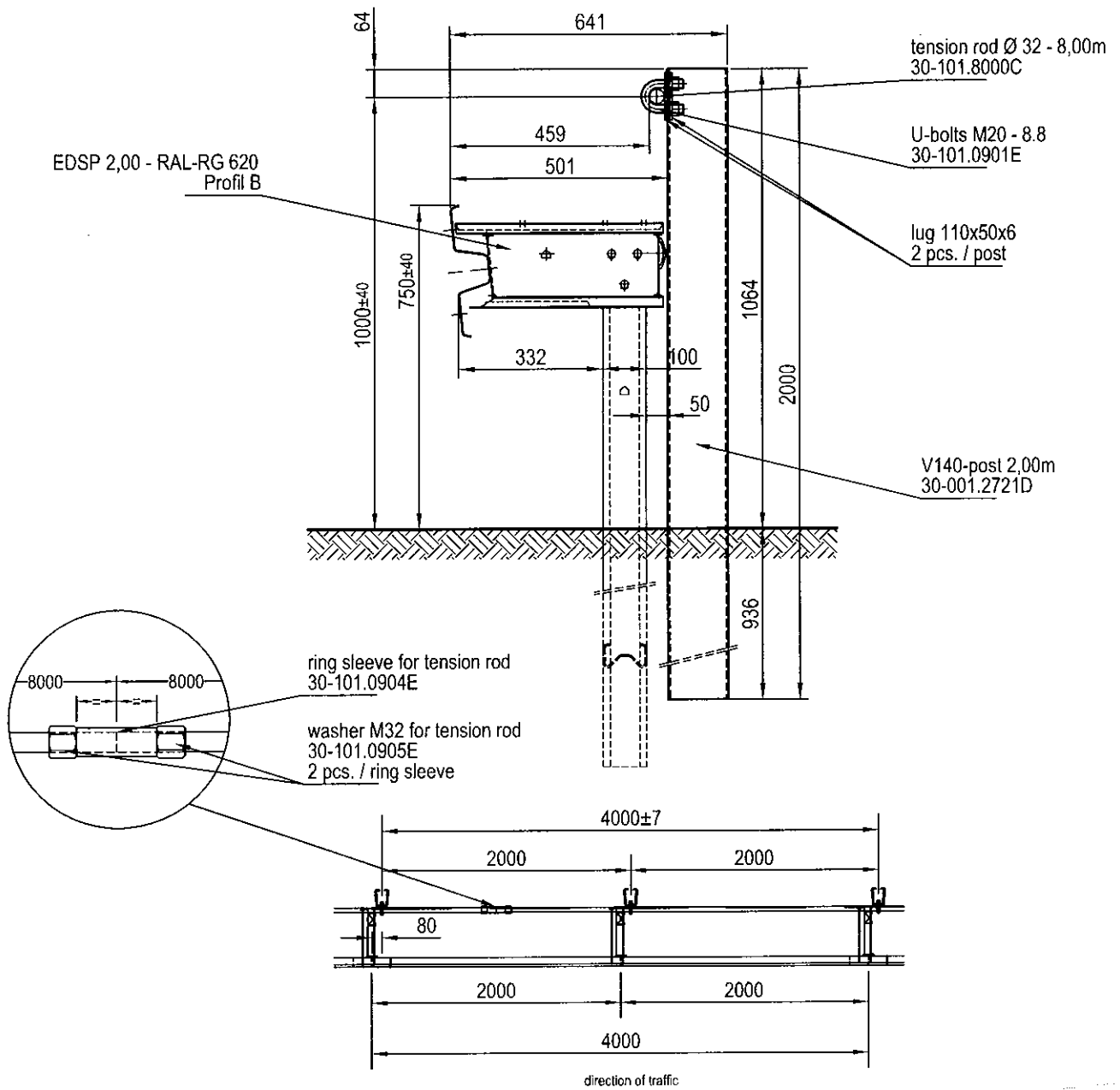

LS Oktober 2007

KREMSBARRIER B RH2 A

Road Restaint System suitable
for pile driving ground conditions

product specifications Sheet CB01/3

installation drawing

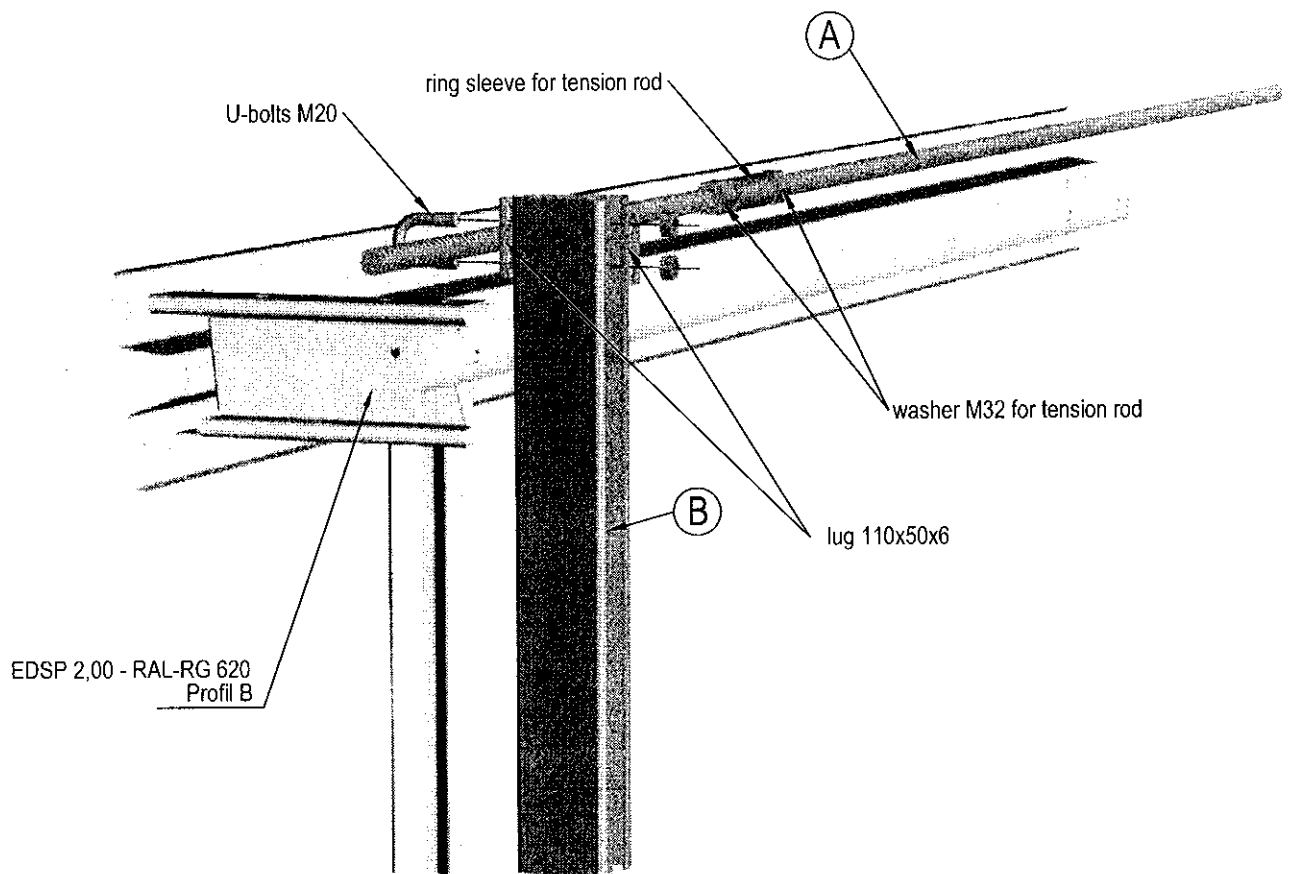

(A)	tension rod \varnothing 32
(B)	V140-post

LS Oktober 2007